

# 3V-SG (Virtual Verification & Validation using vECU Study Group) with ASAM

Akira Watanabe

Dr. Norifumi Yoshimatsu

8th October, 2021



Association for Standardization of  
Automation and Measuring Systems

# Agenda

<b>1</b>	<b>Background</b>
<b>2</b>	<b>vECU-MBD Working Group</b>
<b>3</b>	<b>3V-SG</b>
<b>4</b>	<b>Collaboration on ASAM XCP</b>
<b>5</b>	<b>Summary</b>

# 1. Background (1/2)

## Advancement in automobiles

- To meet demand from both market and society automobiles keep advancing.
- It causes ever increasing in both complexity and scale in electronic control unit (ECU).
- On the other hands, shorten TAT (turnaround time) and lowering cost while keeping reliability are continuously required for development of ECU.

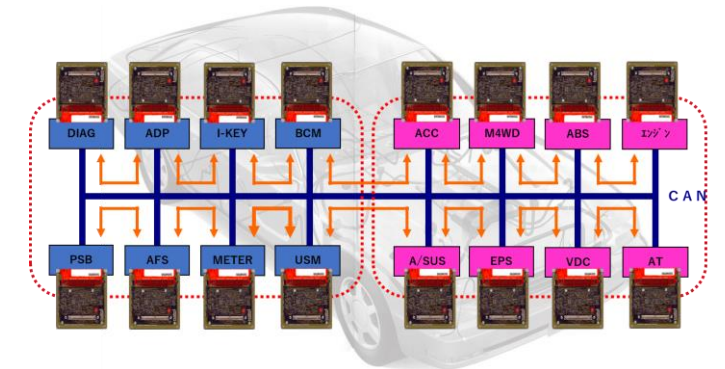

It is necessary to make development of ECU more efficient

# 1. Background (2/2)

## Challenges in applying MBD

- Applying model-based development (MBD) expected to enable efficient development of ECU.
  - It could move forward testing functionality of ECU into upstream or left-hand side of the V-process, then it could reduce both time and cost to develop ECU.
- However, there were many issues pointed out to apply MBD for development of ECU in development site.

Shorten TAT by shifting test to upstream

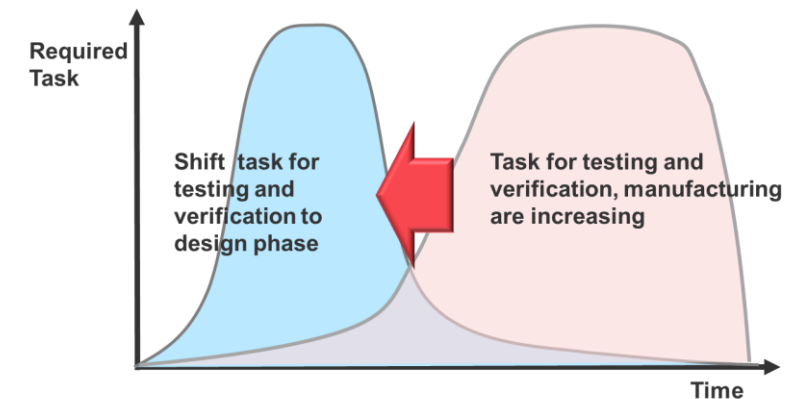

There are issues to apply MBD

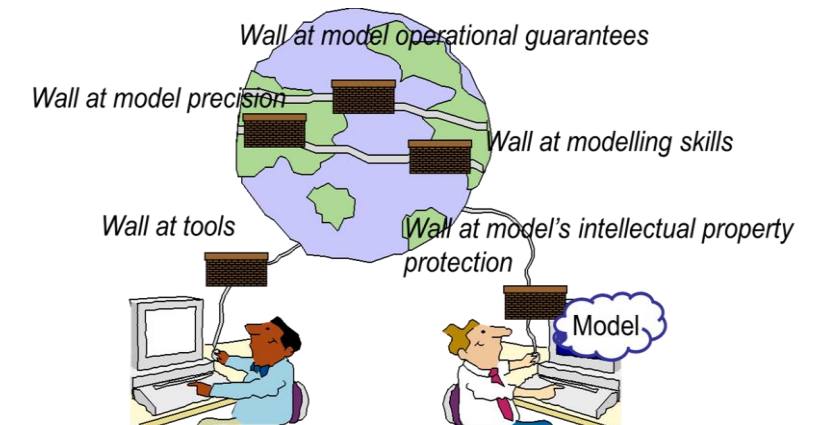

To tackle the issues, we started collaboration between car manufactures, suppliers, semiconductor companies, and tool vendors who work on development of ECU.

## 2. vECU-MBD Working Group

### Overview

- **Objective**

Promote Model-Based Development using virtual ECU.

- **Working group members**

Engineers and researchers from car manufactures, suppliers, semiconductor companies, tool vendors and research organizations related to development of ECU.

- **Activity Started**

April 2010

- **Web**

<http://www.vecu-mbd.org/en/>

- **Activities**

- Publish guidelines on introducing MBD.
- Develop proof of concept (PoC) models.
- Enlightenment of MBD.

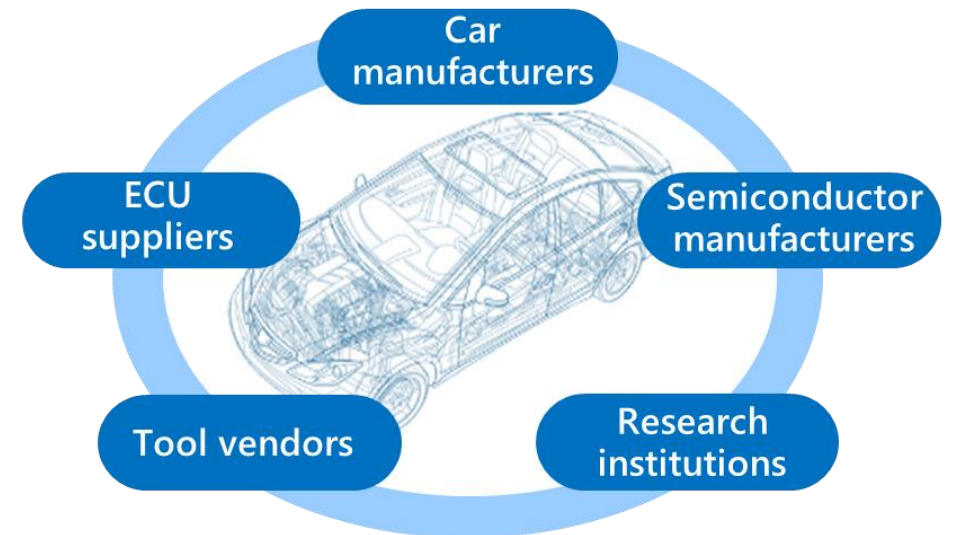

## 2. vECU-MBD Working Group

Focused area

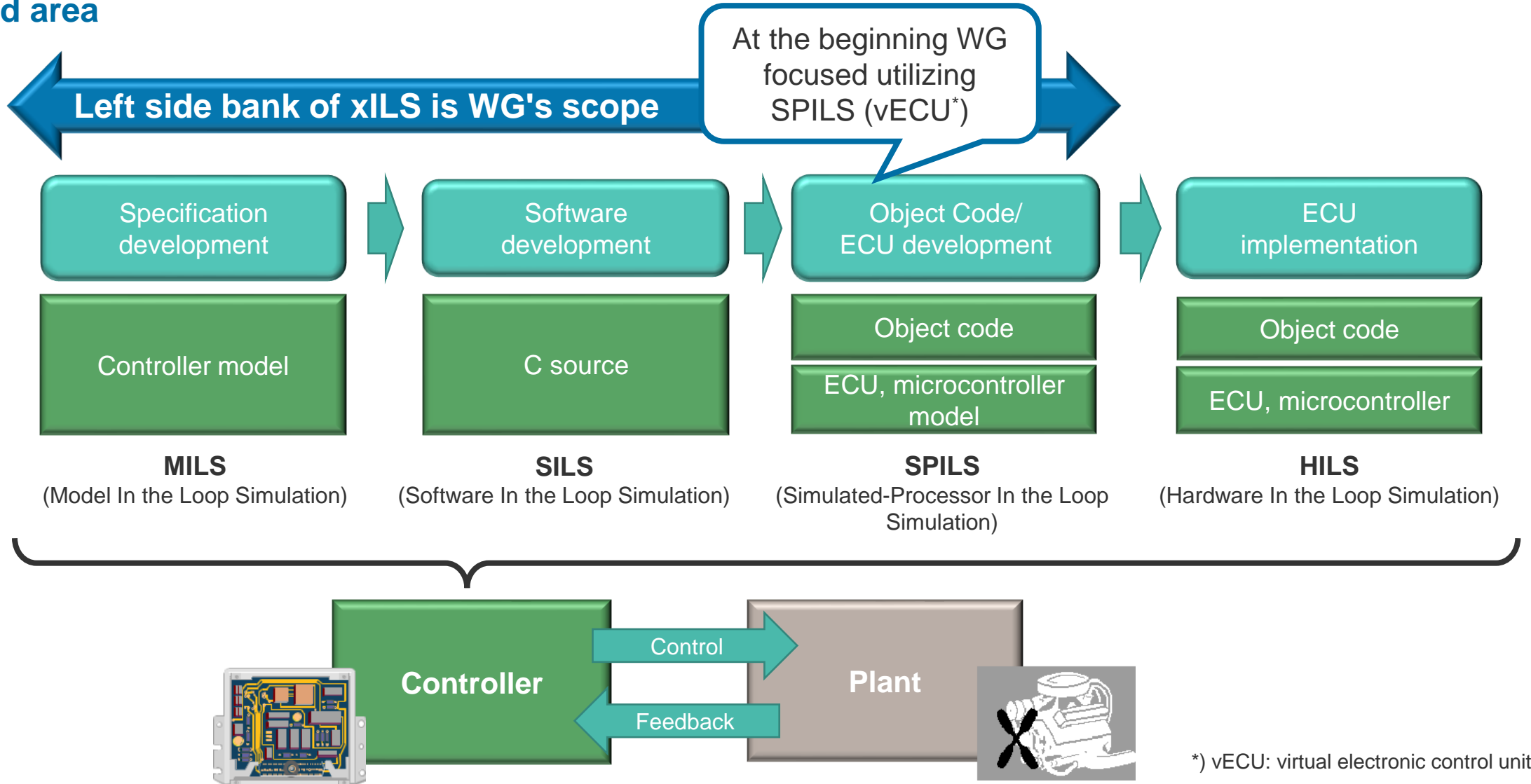

## 2. vECU-MBD Working Group

### Development of models for Proof of Concept (1/3)

In order to promote MBD, PoC models were developed. Basically, PoC models are use-case based.

Main PoC cases are

- Fault injection using vECU.
- Collaborative development in the Cloud.

## 2. vECU-MBD Working Group

### Development of models for Proof of Concept (2/3)

- Fault injection using vECU

Demonstrates how to utilize vECU for verification in case fault occurred in ECU.

- Shows vECU could be an efficient way for fault cases comparing to existing actual system based.
- Verification for the functional safety.
- Two kinds of fault cases are demonstrated in scenario of verifying fail safe functionality in ECU software.
  - Fault in discrete parts
  - Fault in memory
- Tool setup  
Three kinds of tools are connected.
  - Microcontroller: Virtualizer(Synopsys) / No1 System Simulator(Gaio)
  - ECU circuit: Saber(Synopsys)
  - Physical model: Simulink (MathWorks)

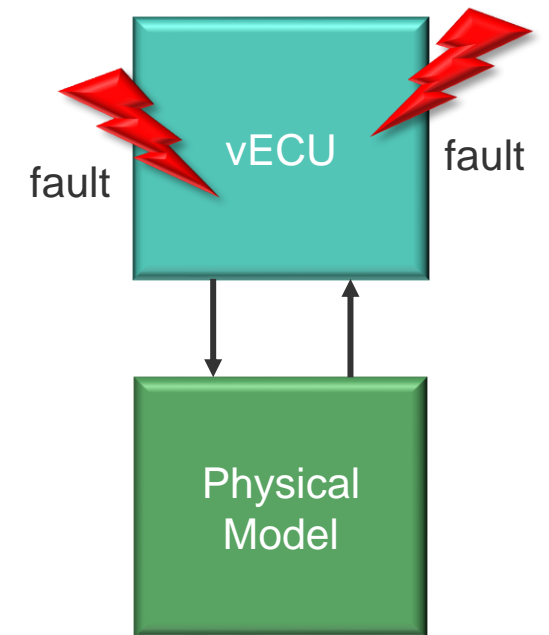

Fault injection in vECU



## 2. vECU-MBD Working Group

### Development of models for Proof of Concept (3/3)

- Collaborative development in the Cloud.

Demonstrate collaborative development using MBD in the cloud.

- A way to collaborate engineers from different companies, it could solve intellectual property issue in case of sharing models for simulation.

We call the way of collaboration as 'Collaborative MBD' or Co-MBD for short.

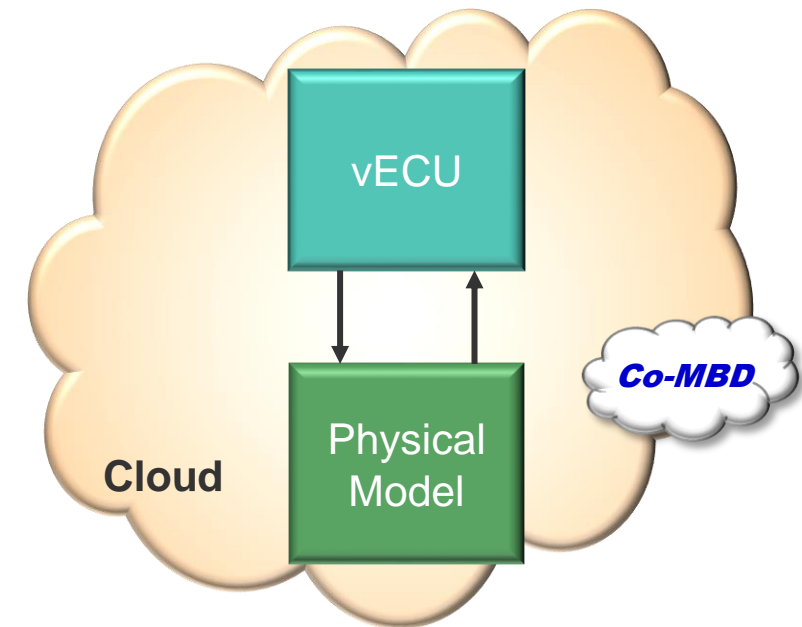

Collaborative development realized in the Cloud.

# Co-MBD (Collaborative MBD)

## Background

### Sharing models between different companies

- When engineers use MBD, it is required to gather all the models used in a simulation.
- Models are often provided by other companies such as other car manufactures, suppliers, semiconductor companies.
- The model providers do not want to show content of models which may include valuable know-how, or intellectual property belong to them.



### Issue: protect intellectual property right

How to protect intellectual property of the model while sharing the model with other companies ?

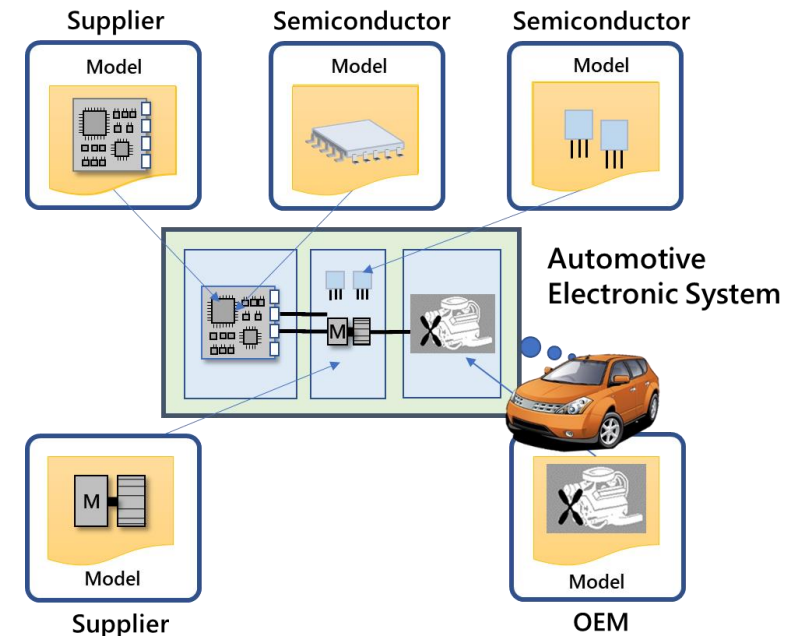

# Co-MBD (Collaborative MBD)

## Model sharing using Model as a Service (MDaaS)

Model provider



Model user

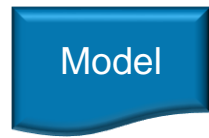

Plain model  
→

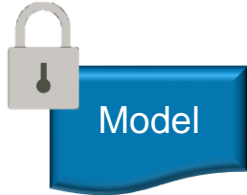
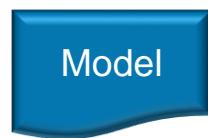

Encrypted model  
→

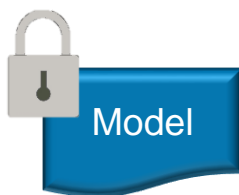

Execution result  
→



How to share models	Model location	Model disclosure
Share plain model	X User side	X Disclose
Share encrypted model	X User side	O Not disclose
Share execution result	O Provider side	O Not disclose

Models as a Service (MDaaS)

O: preferable, X: not preferable

# Co-MBD in the cloud

## Concept

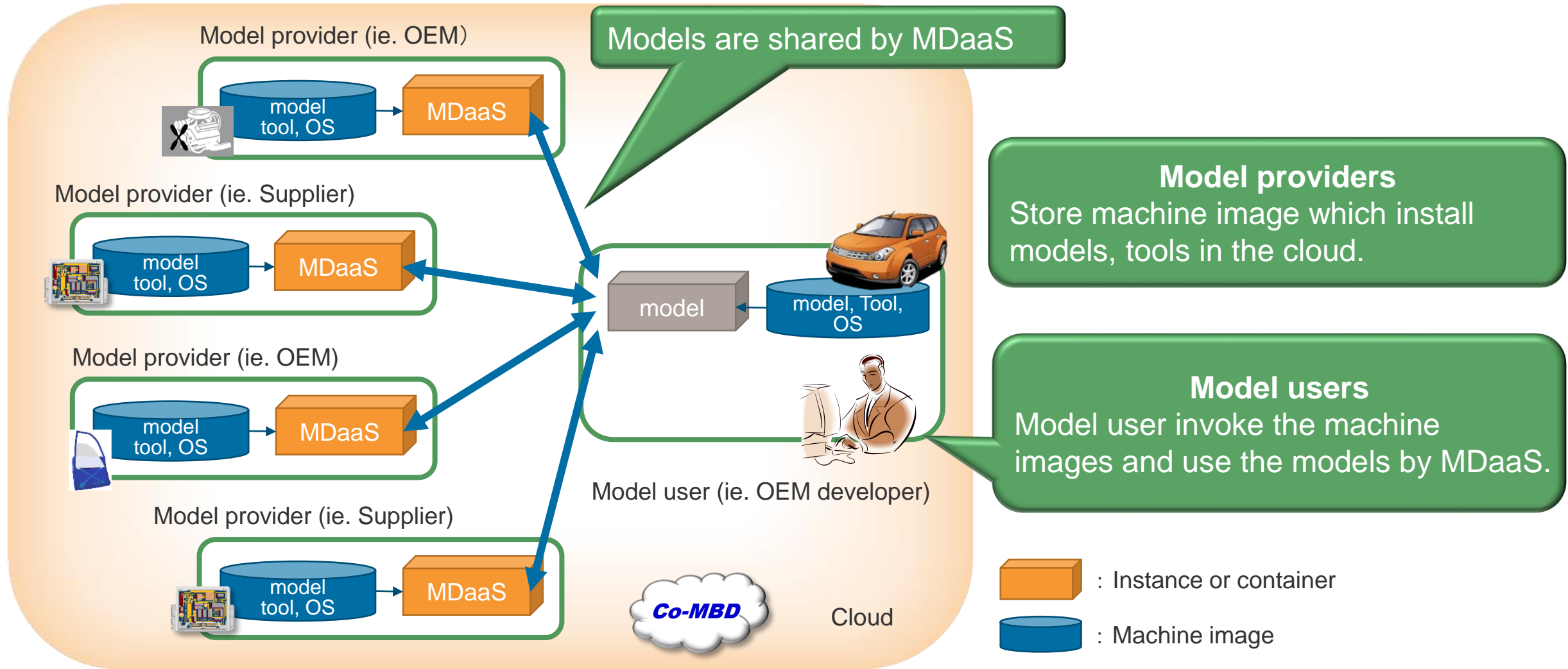

# Co-MBD in the cloud

Contents of models are not disclosed

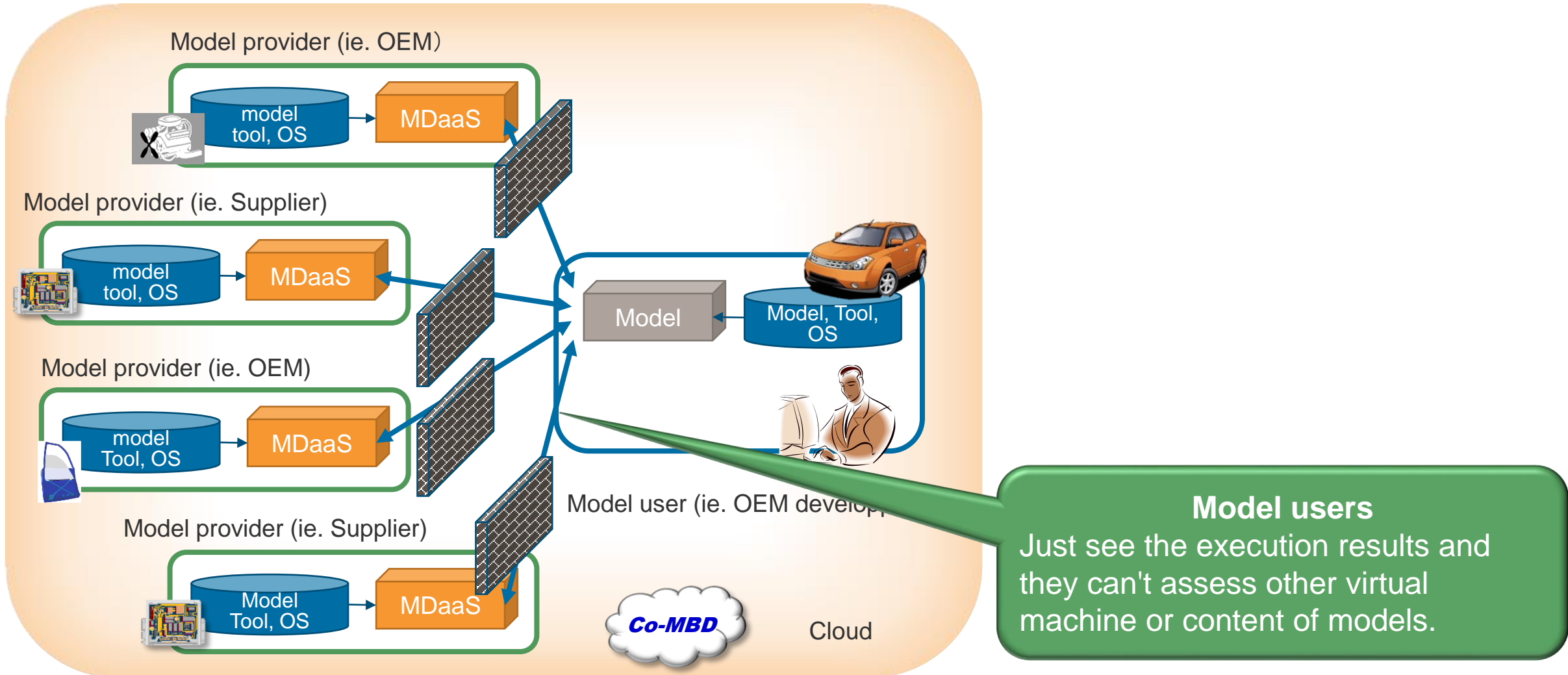

# Co-MBD in the cloud

## Proof of Concept

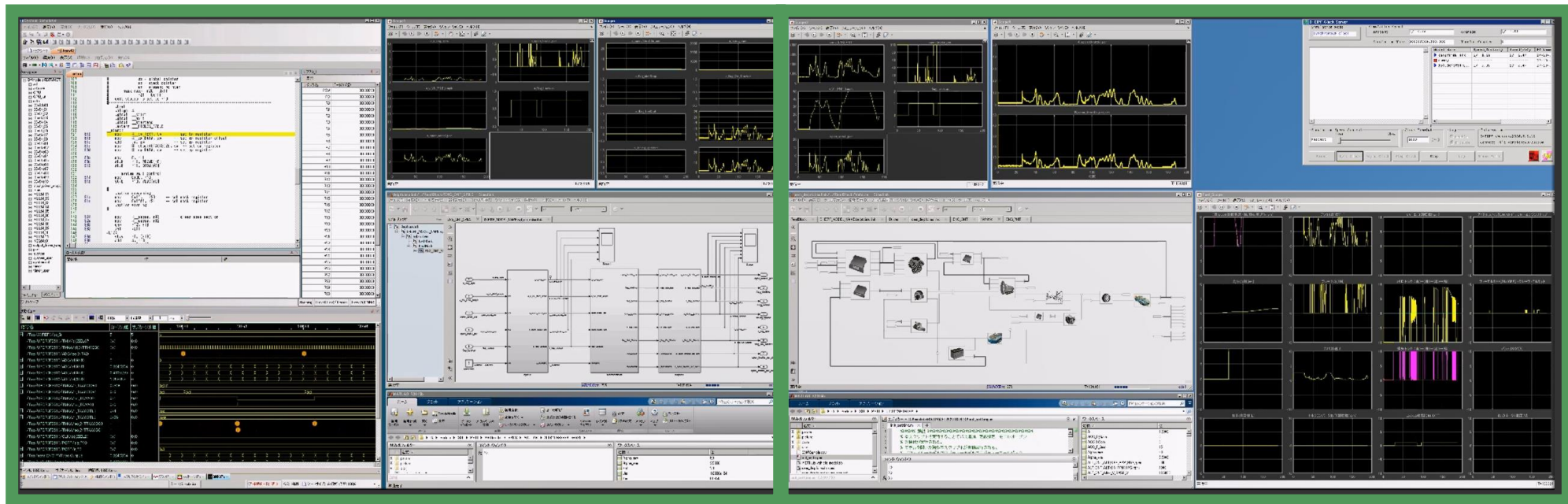
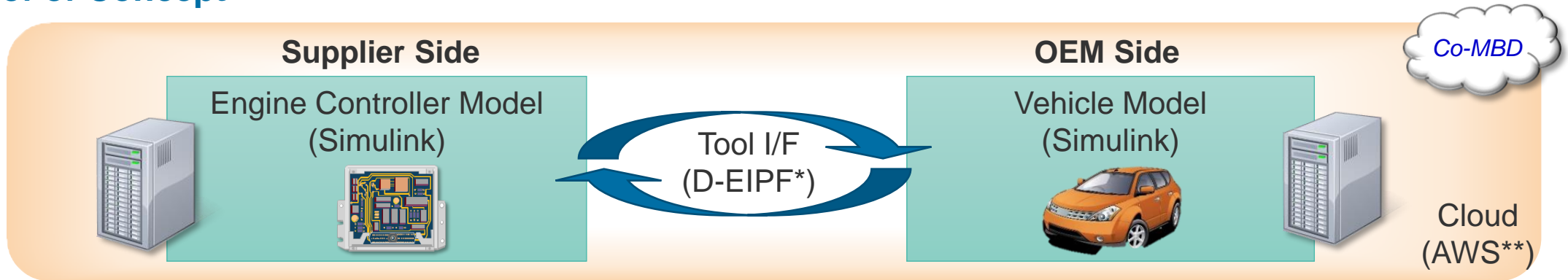

\*) D-EIPF: Design Electronic Integration PlatForm, \*\*) AWS: Amazon Web Service

# Agenda

<b>1</b>	<b>Background</b>
<b>2</b>	<b>vECU-MBD Working Group</b>
<b>3</b>	<b>3V-SG</b>
<b>4</b>	<b>Collaboration on ASAM XCP</b>
<b>5</b>	<b>Summary</b>

## 4. 3V-SG

### Background

- As represented by CASE, both technology and the demands from society around automobiles are changing rapidly.
- Automotive electronic system becomes more important to meet the demands. And as its functionalities grow, scope of verification and validation for the automotive electronic system expands.
- To respond to the change, we shift our activities to studying virtual verification methods more widely.
- We started to 3V-SG (**V**irtual **V**erification & **V**alidation using **v**ECU **S**tudy **G**roup).



## 4. 3V-SG

### Transition to 3V-SG

**vECU-MBD WG**



2010~2021

WG primary focuses on use cases and enlightenment related to vECU.

**3V-SG (Virtual Verification & Validation using vECU Study Group)**

2021~

- SG widely studies virtual verification methods as one of the verification methods.
- In case useful outcomes obtained from studies, SG takes into consideration to advocate standardization.

## 2. 3V-SG

### Overview

- **Objective**

3V-SG widely studies "virtual verification methods" as a means of verification and evaluation.

Disseminate proposals on technologies and development methods those enable efficient development of mobility systems.

- **Organization**

General meeting, Steering committee, and Task forces that carries out specific activities.

- **Web**

<https://www.3vsg.org/en>



## 4. 3V-SG

### Members' organization

- NISSAN MOTOR Co. Ltd.
- Mazda Motor Corporation
- Marelli Corporation
- Bosch Corporation
- Hitachi Astemo, Ltd.
- Hitachi Industry & Control Solutions, Ltd.
- Toyota Technical Development Corporation
- Renesas Electronics Corporation
- TOSHIBA Digital Solutions Corporation
- Nihon Synopsys G.K.
- GAIO TECHNOLOGY Co., Ltd.
- Cadence Design Systems, Japan
- ETAS K.K.
- InterBuddy Inc.
- T2 Laboratory Co. Ltd.
- Australian Semiconductor Technology Company
- dSPACE Japan K.K.
- Tokyo Computer Service Co., Ltd.
- MoDeCH Inc.
- Ryoden Corporation
- SYNKOM Co., Ltd.
- WITZ Co., Ltd.
- TechnoPro, Inc. TechnoPro Design Company
- ASAM Japan, LLC.

24 organizations (as of Oct. 2021)

## 4. 3V-SG

### Field of interest

3V-SG's field of interest includes following areas (not limited) where they could utilize virtual verification and validation to achieve efficient development of mobility systems.

- Model-based development (MILS、SILS、SPILS、HILS)
- Tools and models
- Machine infrastructure (cloud, network)
- Functional Safety
- User interface, Debug interface
- Multi-core CPUs
- Development processes
- Model exchange
- Systems engineering
- Continuous Integration/Continuous Test
- Data for verification and/or validation
- Security

## 2. 3V-SG

### Task forces

- **ASAM Collaboration**

The task force evaluates ASAM XCP in the cloud environment. Especially, a case multiple users from different organization access target systems using ASAM XCP in the virtual environment.

- **METI-SPILS**

The task force studies design methodology to streamline generating models for vECU, and studies design methodology for fault injection using vECU, utilizing vehicle model from METI\*1.

- **FMI Collaboration**

The task force evaluates FMI\*2 and eFMI\*3 by collaborating with committee members of JSAE\*4 who are also working on these standards.

More activities are under discussion.

\*1 METI: Ministry of Economy, Trade and Industry

\*2 FMI: Functional Mock-up Interface

\*3 eFMI: Functional Mock-up Interface

\*4 JSAE: Society of Automotive Engineers of Japan, Inc.

# Agenda

<b>1</b>	<b>Background</b>
<b>2</b>	<b>vECU-MBD Working Group</b>
<b>3</b>	<b>3V-SG</b>
<b>4</b>	<b>Collaboration on ASAM XCP</b>
<b>5</b>	<b>Summary</b>

# 3. Collaboration on ASAM XCP

## Co-MBD using virtual-HILS on Cloud

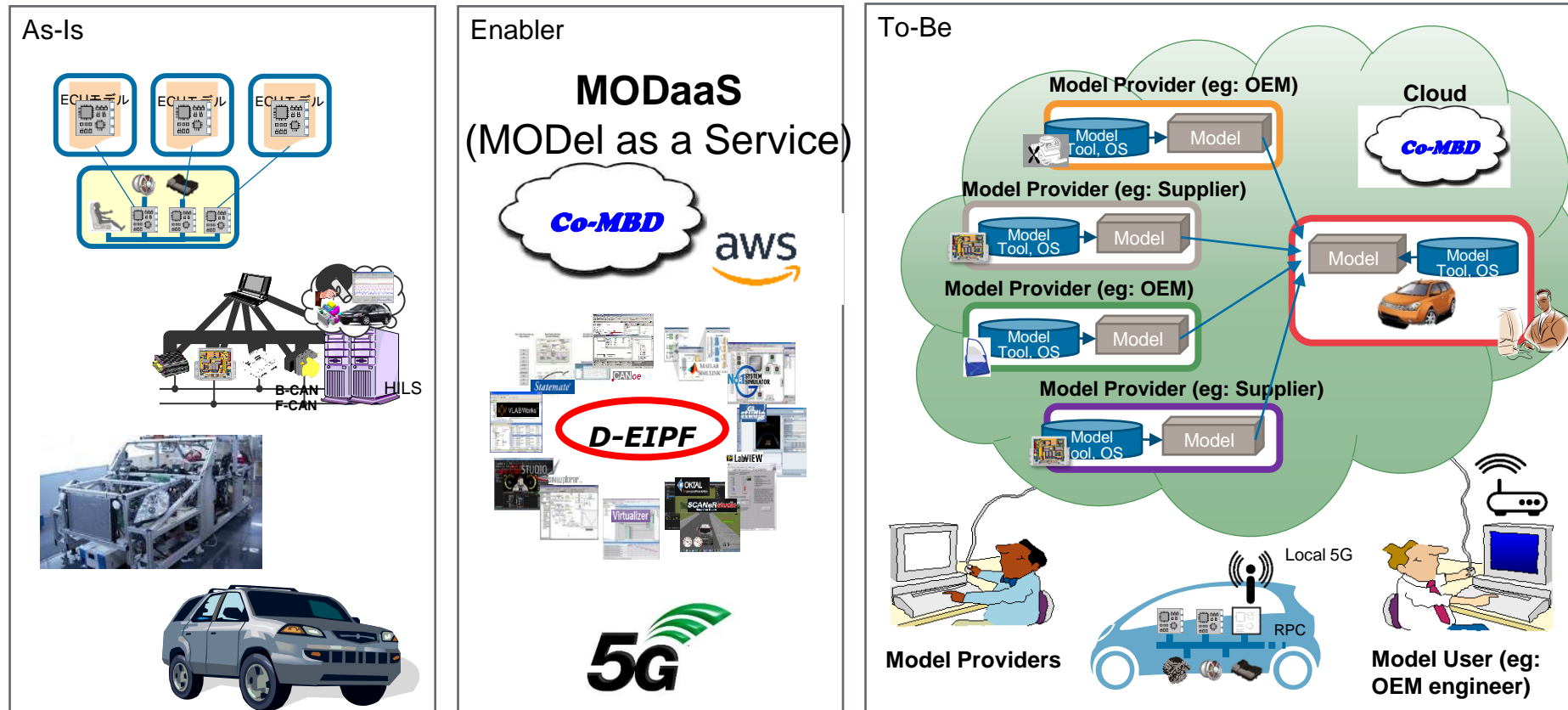

### 3. ASAM XCP and Co-MBD

#### Feasibility study for using ASAM at co-simulation of different users on cloud (Co-MBD)

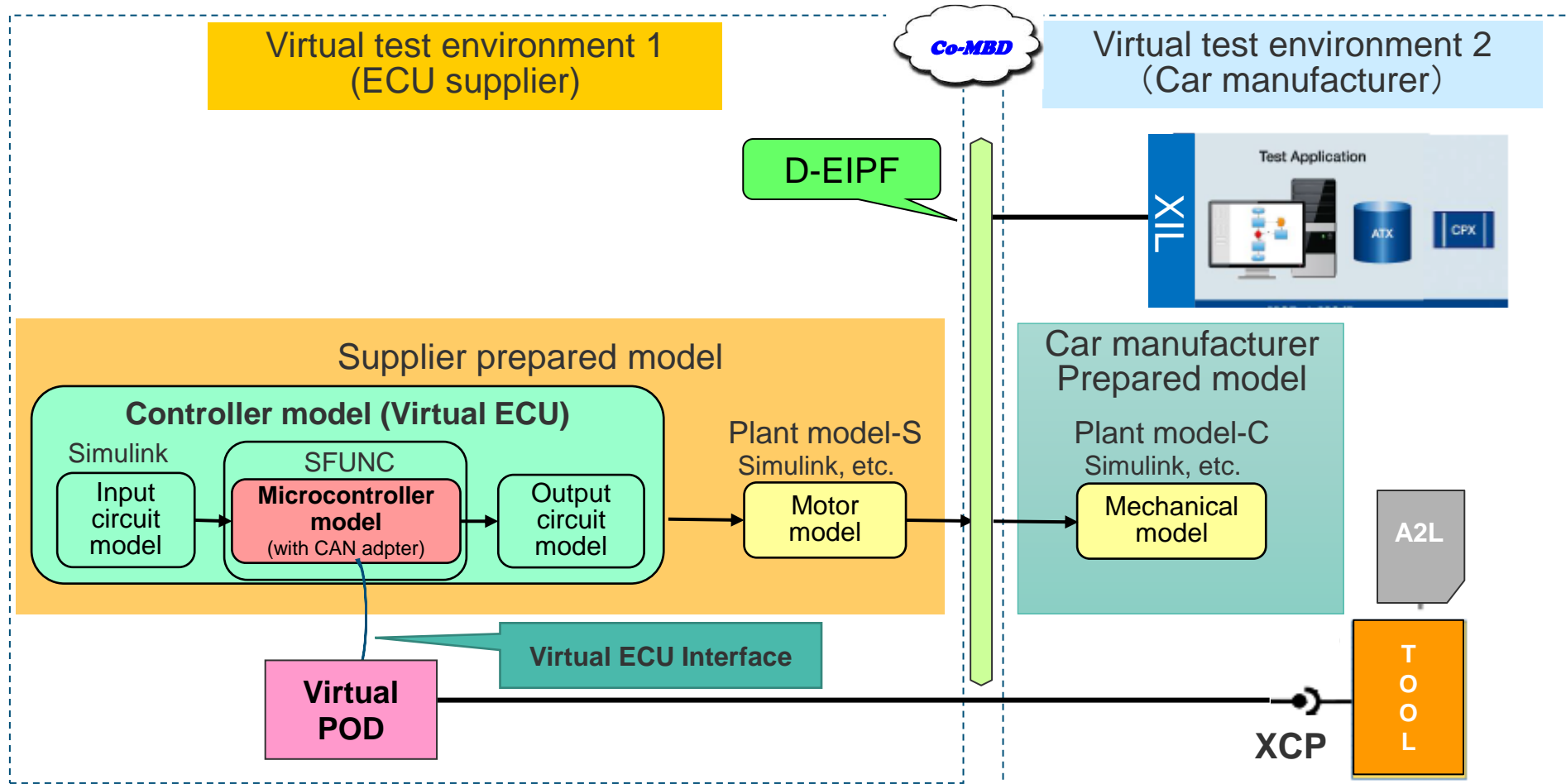

ASAM XIL : an API standard for the communication between test automation tools and test benches  
ASAM MCD-1 XCP : a bus-independent, master-slave communication protocol to connect ECUs with calibration systems  
POD : Plug-On Device



# Concerns and Issues to use MC on virtual environment

Will add in case we face any concerns/issues.

No	Item	Description	Countermeasure	Note
1	Startup sequence	If startup sequence is different among vECUs, there is a concern that synchronous measurement is not possible. (e.g. MC tool should be start first, or simulator started first...) Startup sequence of vECU should be flexible and not depend on the specific order.	To be confirmed in future.	
2	Restriction by security mechanism on execution environment	Due to security mechanism on PC which MC tool or vECU is set on, not possible to change configuration of network and firewall. For this MC tool PC and vECU PC cannot be connected.	Use PCs on which the configuration of NW and firewall can be changed.	In the case that device license is needed to install vECU, should be careful for security mechanism of PC.
3	Multi-master connection in cloud environment	ASAM MCD-1 XCP does not allow multi-master topology. On cloud environment there is a possibility that multiple masters connect to a vECU. Ex. During a user is monitoring or calibrating a vECU on cloud, another user may connect to the same vECU.	Implement any exclusive control to vECU. or, Feedback to ASAM if there is use case multi-master connection is necessary.	
4	Seed & Key support	vECU. Is it possible to support Seed & Key mechanism to vECU? (or already supported?)	To be confirmed in future.	
5	Disconnection control between MC tool and vECU	A mechanism to forcibly disconnect XCP communication is needed. (ex. In the case that no one notices that keep MC tool connecting to vECU)	To be confirmed in future.	
6	MC tool on cloud	Restrictions on MC tool: Is it possible to use MC tool on cloud? What kind of restriction will be? (ex. Any restriction of license)	To be confirmed in future.	
7		Multiuser access to MC tool: If MC tool is put on cloud, there is a case multi users will use at the same time. The number of user will be limited?	To be confirmed in future.	
8		Location of A2L file: If MC tool is put on cloud, where should A2L file be put? (Cloud server where MC tool is installed, or user's local PC?)	To be confirmed in future.	
9	Timeout setting in A2L	For vECU the timeout value for command-response defined in A2L is different from real ECU.	To change the value in A2L or setting of MC tool.	

# Concern No.9 : Timeout setting

## Environment

MC tool

- INCA V7.2.5\*1
- CANape V16.0 SP5\*2

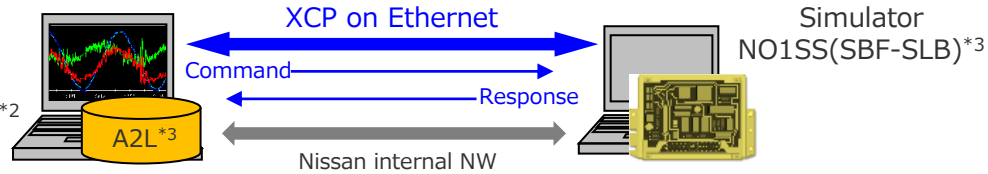

\*1: ETAS  
\*2: Vector  
\*3: GAIO

## Timeout error occurred.

- XCP communication between MC tool and simulator was disconnected.
- Timeout error was displayed on the screen of MC tool.
- Timing of disconnection was indefinite.

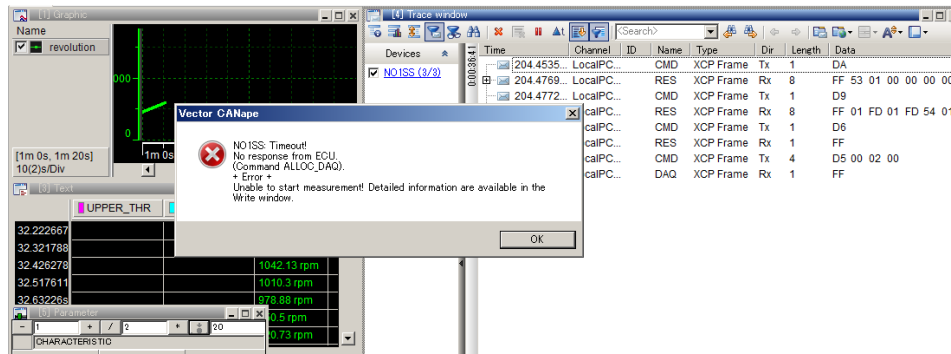

## Findings

Issue was avoidable by changing the command-response timeout to the larger.

- **When setting to 10ms, 100ms : Timeout error occurred.**
- **When setting to 1000ms : No error**

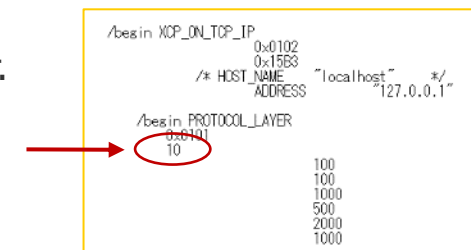

# Concern No.3 : multi-master connection in cloud environment

Ex. During user A (OEM) is monitoring and/or calibrating of vECU, user B (supplier) connects.

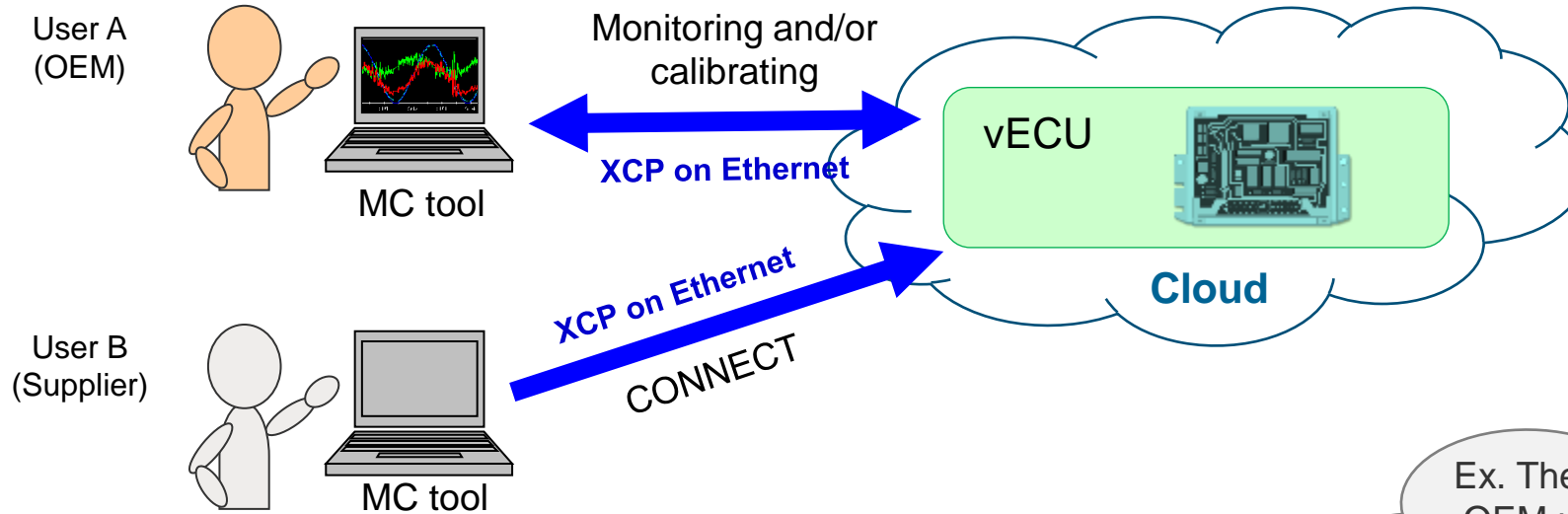

## From ASAM Office;

- MCD-1 XCP does not define a behavioral specification of multi-master connection.
- When multiple masters send CONNECT command with the same IP address and port, slave (vECU) cannot identify the user for each commands.
- Slave will respond to CONNECT commands even if multiple times. However, measurement may stop by command sequence error dependent on what command will be sent from users.
- Need to implement exclusive control mechanism to vECU.

Ex. There might be a case that OEM user would like to share with supplier in real time the transition of variables associated with calibration.

→ To plan to include these cases to trial scenario, and study to give feedback to ASAM if there is use case multi-master connection is necessary

# Action road map of the task force (under discussion)

To ensure using XCP feasibility on cloud environment

Eva. Steps	Evaluation											Remarks
		Number of ECUs		Sim. tool of ECUs		MC Tool Environment		Virt. ECU Environment		Plant model		
		Single	Multi.	same	diff.	Local*	Cloud	Local*	Cloud	No	Yes	
step0	MC tool can be used for a virtual ECU.	X		X		X		X		X		Environment of MC tool and Virtual ECU: on-premise
step0.5	MC tool can be used for multiple virtual ECUs. The virtual ECUs use the same simulation tool.	→	X	X		X		X		X		
step1	MC tool can be used for multiple virtual ECUs. The virtual ECUs use different simulation tools.		X	→	X	X		X		X		
Step1.5	MC tool can be used for MILS(Simulink models) .		X		X	X		X		→	X	Under study for details.
step2	MC tool can be used with the step1 configuration in the cloud environment.		X		X	X	→	X	→	X		Environment of MC tool and Virtual ECU: cloud
step3,4	MC tool can be used with step2 configuration, and the virtual ECU also runs in the cloud.		X		X	X	X		X	→	X	Evaluation model: power window system
step5	A simple vehicle model is used.		X		X	X	X		X		X	Evaluation model: METI model

black text : done. red text : not done yet.

\*) local : means on-premis

X : setup used in the evaluation (blue: evaluation item at this step)

# Task force members

Here is the member list and should say grateful for them dedicated supports.

- Australian Semiconductor Technology Company K.K.
- ETAS K.K.
- GAIO TECHNOLOGY Co., Ltd.
- Nihon Synopsys G.K.
- Nissan Motor Co., Ltd.

The task force are considering adding more members depending on the roadmap in the future.

# A goal image at step 5

Scope of PoC is expanded (not only SPILS but also **MILS**).

We will study the use case for MILS and verify whether we can use MC tool in the same way as real ECU or SPILS environment.

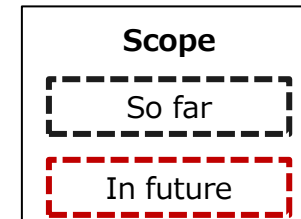
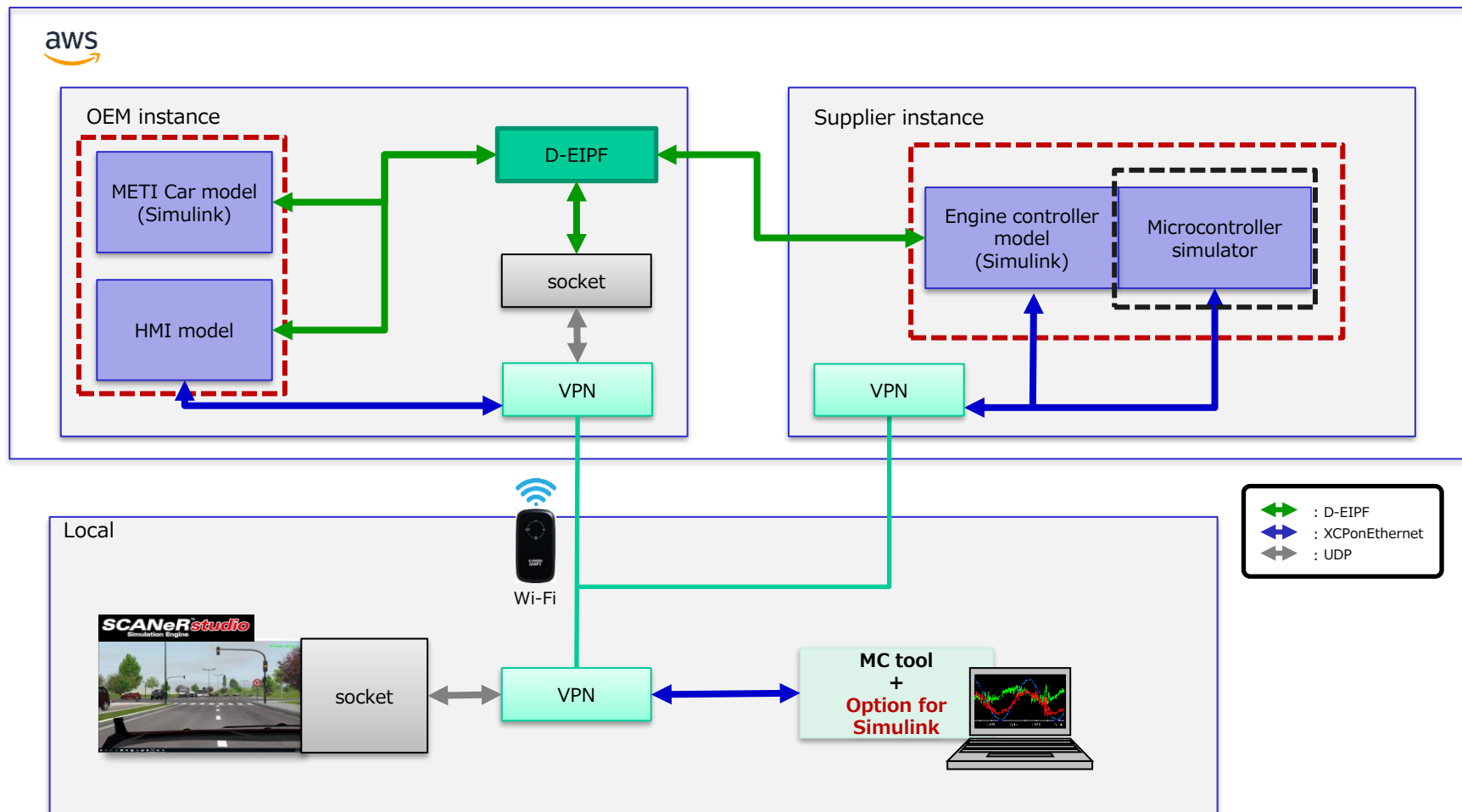

## In the future

We would like to give feedback about findings gotten through vECU-WG to ASAM standards.

### Relevant standards

- MCD-1POD
- MCD-1XCP
- MCD-2MC

## 4. Summary

- **Engineers and researchers in the industry involved in model-based development of in-vehicle electronic systems** collaborate to solve problems in utilizing model-based development. Create / publish, demonstrate, propose, and raise awareness of guides that guide the use of model-based development.
- From vECU-MBD WG to 3V-SG.  
**Widely research "virtual verification methods"** as a means of verification and evaluation. And provide and widely disseminate proposals on technologies and development methods for realizing the development and efficiency of mobility systems.
- We are looking forward **to advance virtual verification methods by collaborating with ASAM.**

